

Switching Power Transformers



We manufacture a wide variety of transformers featuring compactness and high reliability for consumer, industrial electronics, communication equipment and other electronic equipment according to their applications. Matching a large variety of ferrite core sizes, vertical and horizontal bobbins of various types are available to meet optimal design.

APPLICATIONS:

Power supply of Telecommunications, AV Products, TV, DVD/VCD, Scetellite receiver, industrial and Consumer products.

FEATURES:

- Compactness and lightweight.
- Low power loss & high magnetic flux density.
- Easy mounting on printed wiring boards.
- High safety using abundant fire-retardant materials.
- High dielectric withstand satisfies safety standards.
- UL Approved insulation material used.
- Excellent efficiency.
- Meet UL1950, IEC950, EN60950, CE etc international safety standard.

GENERAL CHARACTERISTIC:

Power Capacity: 5Watts to 5000 Watts +
Operating Frequency: 20KHz to 500KHz +

Available Ferrite Core size :

- EE-5 ~ EE70
- EER9 ~ EER-60
- ETD-24 ~ ETD59
- PQ-20 ~ PQ50
- RM4 ~ RM-14
- EFD13 ~ EFD-30

Operating Temperature: up to 155°C

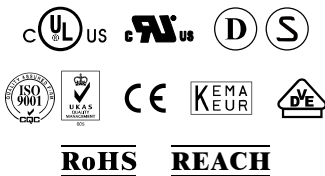

Additional information:

We reserve the right to make technical changes or modify the contents of this document without prior notice. SHARE Ltd. Does not accept any responsibility what so ever for potential errors or possible lack of information in this document.

We can offer that even custom-made transformers will be covered by approvals from UL, CSA, KEMA, etc., but we will be happy to assist you in implementing them.

New approvals may be required.

SH-EE,SH-EI SERIES SWITCHING POWER TRANSFORMER



FEATURES

Possessing of high permeability
High saturation flux density
Low loss, at 100°C the power loss goes bottom

Bulk packaging is standard
Custom design available

Drive transformers
Main transformers
Smoothing chokes
General purpose use



Additional information:

We reserve the right to make technical changes or modify the contents of this document without prior notice.

SHARE Ltd. Does not accept any responsibility what so ever for potential errors or possible lack of information in this document.

We can offer that even custom-made transformers will be covered by approvals from UL, CSA, KEMA, etc., but we will be happy to assist you in implementing them. New approvals may be required.

Part No.	Type	PIN	Dimensions(mm)						Max. output (VA)
			Max A	Max B	Max C	±0.3 D	±0.5 E	±0.1 F	
SH-EI 8.3-A	V	6	8.5	8.5	9.0	2.5	6.0	0.5	3
SH-EE 8.3-B	H	6	8.5	8.5	7.0	2.5	6.0	0.5	3
SH-EE 8.3-C	H	4	8.5	9.5	9.0	5.0	6.8	0.5	3
SH-EI 10-A	V	8	10.5	11.0	11.0	2.5	8.0	0.5	5
SH-EI 10-B	H	8	11.0	13.0	10.5	2.5	10.5	0.5	5
SH-EI 10-C	H	4	10.0	9.5	10.0	5.0	6.8	0.5	5
SH-EI 12.5-A	V	10	13.0	13.0	10.0	2.5	7.5	0.6	8
SH-EE 12-A	H	4	12.5	11.0	12.5	8.0	9.0	0.6	8
SH-EE 13-A	V	10	13.5	13.0	12.0	2.5	8.7	0.6	9
SH-EI 14-A	V	6	14.5	14.5	13.0	3.5	11.0	0.6	15
SH-EE 16-A	V	6	16.5	13.5	13.0	3.0	9.0	0.6	25
SH-EE 16-B	H	8	16.5	14.5	15.0	3.0	11.0	0.6	25
SH-EE 16-C	H	8	16.5	14.5	15.0	3.5	12.0	0.6	25
SH-EE 16-D	V	10	16.5	13.5	14.5	3.25	10.5	0.6	25
SH-EE 16-F	H	10	16.5	19.0	14.0	3.2	15.5	0.8	25
SH-EEL 16-A	V	10	22.0	16.5	30.0	4.0	10.3	0.6	25
SH-EE 19-A	V	6	20.0	18.0	18.0	4.1	14.0	0.7	35
SH-EE 19-B	V	6	20.0	16.0	18.0	4.7	11.6	0.6	35
SH-EE 19-C	H	8	20.0	18.0	16.5	3.8/5	12.5	0.7	35
SH-EEL 19-A	V	8	20.0	20.5	32.0	3.8/4.8	15.0	0.8	35
SH-EEL 19-B	H	6	19.5	32.0	13.0	5	24.2	0.8	35
SH-EEL 19-C	V	10	23.0	16.5	32.0	4	10.0	0.8	35
SH-EE 20-A	H	8	20.5	19.0	13.0	5	15.0	0.8	35
SH-EE 22-A	V	10	22.5	16.5	20.0	4	10.2	0.8	45
SH-EE 22-B	V	8	22.5	17.0	20.0	5	12.4	0.8	45
SH-EE 22-C	H	9	22.5	24.5	16.5	3.5/5	17.2	0.8	45
SH-EE 25-A	V	8	25.5	18.0	22.0	5	12.4	0.8	65
SH-EE 25-B	V	10	26.0	20.5	22.0	5	15.2	0.8	65
SH-EE25-C	H	10	27.0	24.0	24.0	4.0/5	14.6	0.8	65
SH-EEL 25-A	H	14	27.5	33.5	21.0	4.0	27.1	0.8	65

Part No.	Type	PIN	Dimensions(mm)						Max. output (VA)
			Max A	Max B	Max C	±0.3 D	±0.5 E	±0.1 F	
SH-EL 25-B	V	14	27.5	21.0	35.0	4.0	15.0	0.8	65
SH-EI 28-A	V	12	29.5	25.0	24.0	5.0	17.5	0.8	100
SH-EI 28-B	V	10	28.5	25.0	35.0	5.0	20.0	0.8	100
SH-EI 28-C	H	8	28.5	25.0	25.0	5.0	17.5	0.8	100
SH-EI 30-A	V	10	31.0	22.0	26.0	5.0	17.6	0.8	155
SH-EI 30-B	V	12	31.0	26.0	26.0	5.0	20.0	0.8	155
SH-EE 30-A	H	10	30.5	30.0	20.5	5.0	25.0	0.8	155
SH-EE 30-B	H	12	30.5	30.0	20.5	5.0	25.0	0.8	155
SH-EI 33-A	V	14	34.0	28.0	30.0	5.0	22.5	0.8	200
SH-EI 33-B	V	12	34.0	28.0	30.0	5.0	22.5	0.8	200
SH-EI 33-C	V	16	39.0	29.0	30.0	5.0	22.5	0.8	200
SH-EE 35-A	H	12	38.0	30.0	26.0	3.8/5.1	22.0	0.8	215
SH-EE 35-B	V	10	35.5	26.0	28.0	5.0	20.0	0.8	215
SH-EE 35-C	V	14	35.5	26.0	28.0	5.0	20.0	0.8	215
SH-EEL 35-A	V	15	36.5	27.5	50.0	5.0	22.5	0.8	215
SH-EI 35-A	V	12	35.5	28.5	29.0	5/7.5	20.0	1.0	215
SH-EI 40-A	V	12	40.5	29.0	32.0	5.0	22.5	0.8	345
SH-EI 40-B	H	12	40.5	37.0	27.0	5.0	28.2	1.0	345
SH-EI 40-C	V	16	42.0	28.0	35.0	5.0	22.5	0.8	345
SH-EI 40-D	H	14	40.5	35.0	29.0	5.0	25.8	0.8	345
SH-EE 42-A	H	16	44.5	42.0	41.5	5.0	34.0	1.0	400
SH-EE 42-B	H	12	47.0	42.0	39.5	5/7.5	33.0	1.0	400
SH-EE 42-C	V	18	46.0	32.5	46.0	5.0	27.5	1.0	400
SH-EE 42-D	V	12	46.0	42.5	37.0	7.4	36.4	1.0	420
SH-EE 42-E	V	12	43.0	40.5	45.0	5.0	32.5	1.0	420
SH-EE 42-F	H	17	43.0	47.0	45.0	2.5/5	37.7	1.0	420
SH-EE 42-G	V	18	46.0	38.0	47.0	5.0	30.0	1.0	420
SH-EE 50-A	V	18	51.0	40.0	40.0	5.0	30.5	1.0	500
SH-EE 55-A	H	20	56.0	55.0	50.5	5/7.5	45.2	1.0	814

Note: The output power is only for forward model and the frequency at 100kHz

MECHANICAL DRAWING (mm)

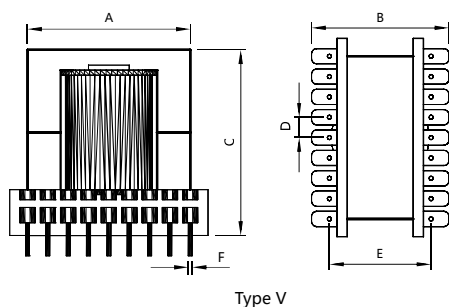

Type V

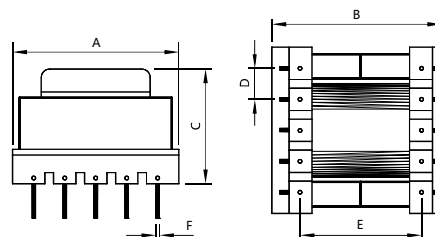

Type H

SH-ER SERIES SWITCHING POWER TRANSFORMER

FEATURES

Center section of the core is round
easily design high-powerswitch transformers
Low leakage

Bulk packaging is standard
Custom design available

Drive transformers
Main transformers
Smoothing chokes
General purpose use



Additional information:

We reserve the right to make technical changes or modify the contents of this document without prior notice.

SHARE Ltd. Does not accept any responsibility what so ever for potential errors or possible lack of information in this document.

We can offer that even custom-made transformers will be covered by approvals from UL, CSA, KEMA, etc., but we will be happy to assist you in implementing them. New approvals may be required.



Part No.	Type	PIN	Dimensions(mm)						Max. output (VA)
			Max A	Max B	Max C	±0.3 D	±0.5 E	±0.1 F	
SH-ER 11.5-A	V	8	14	14	12	2.6	9.0	0.6	3
SH-ER 25-A	V	8	27	22	28	5.0	12.5	0.8	87
SH-ER 25-B	V	10	27	22	28	5.0	15.0	0.8	87
SH-ER 28-A	H	20	35	32	25	2.54	28.0	0.5	203
SH-ER 25-B	H	12	31	32	25	5.0	25.0	0.8	203
SH-ER 28-C	V	10	27	25	32	5.0	17.3	0.8	203
SH-ER 28-D	V	12	32	28	32	4.9	22.0	0.6	203
SH-ERL 28-A	V	10	32	25	36	5.0	17.5	0.8	228
SH-ERL 28-B	V	12	32	25	38	5.0	17.5	0.8	228
SH-ERL 28-C	V	12	32	25	36	5.0	20.2	0.8	228
SH-ERL 28-D	V	18	30	25	38	4.0	20.0	0.8	228
SH-ERL 28-E	V	10	30	25	38	5.0	17.5	0.8	228
SH-ERL 28-F	V	14	32	28	38	5.0	20.0	0.8	228
SH-ERL 28-G	H	11	36	38	26	5.0	25.5	0.8	228
SH-ERL 28-H	H	12	32	38	28	5.0	30.4	0.8	228
SH-ER 33-A	V	14	37	31	40	5.0	25.0	1.0	235
SH-ER 33-B	V	14	37	29	40	5.0	22.5	1.0	235
SH-ER 34-A	V	14	36	29	40	5.0	22.3	1.0	240
SH-ER 35-A	V	12	38	30	46	5.0	22.5	1.0	325
SH-ER 35-B	V	14	37	30	44	5.0	22.5	1.0	325
SH-ER 35-C	V	16	41	30	46	5.0	22.55	1.0	325

Part No.	Type	PIN	Dimensions(mm)						Max. output (VA)
			Max A	Max B	Max C	±0.3 D	±0.5 E	±0.1 F	
SH-ER 35-D	H	16	41	45	29	5.0	35.0	1.0	325
SH-ER 35-E	H	12	38	45	27	5.3	37.1	1.0	325
SH-ER 35-F	H	12	45	37	30	5.4	37.1	1.0	325
SH-ER 39-A	V	16	44	32	53	5.0	25.0	1.0	370
SH-ER 39-B	V	14	40	32	54	5.0	25.2	1.0	370
SH-ER 39-C	V	18	45	32	53	5.0	25.0	1.0	370
SH-ER 39-D	H	16	43	45	35	5.0	30.6	1.0	370
SH-ER 39-E	H	16	43	47	35	5.0	35.3	1.0	370
SH-ER 40-A	V	16	42	33	51	5.0	25.2	1.0	421
SH-ER 40-B	V	16	42	34	52	5.0	27.5	1.0	421
SH-ER 40-C	V	12	42	33	48	5.0	25.0	1.0	421
SH-ER 40-D	H	16	42	50	37	5.0	35.2	1.0	421
SH-ER 42-A	V	18	47	33	47	5.0	27.4	1.0	433
SH-ER 42-B	V	14	44	32	49	5.0	24.8	1.0	433
SH-ER 42-C	V	18	47	39	52	5.0	30.2	1.0	509
SH-ER 42-D	H	14	45	45	36	5.0	34.8	1.0	509
SH-ER 49-A	V	22	55	37	62	5.0	27.5	1.0	680
SH-ER 49-B	V	18	52	38	57	5.0	27.5	1.0	680
SH-ER 49-C	V	20	55	41	60	5.0	32.5	1.0	680
SH-ER 53-A	V	18	55	41	55	5.0	32.5	1.0	800
SH-ER 54-B	V	18	60	42	60	5.0	32.0	1.0	850

Note: The output power is only for forward model and the frequency at 100kHz

MECHANICAL DRAWING (mm)

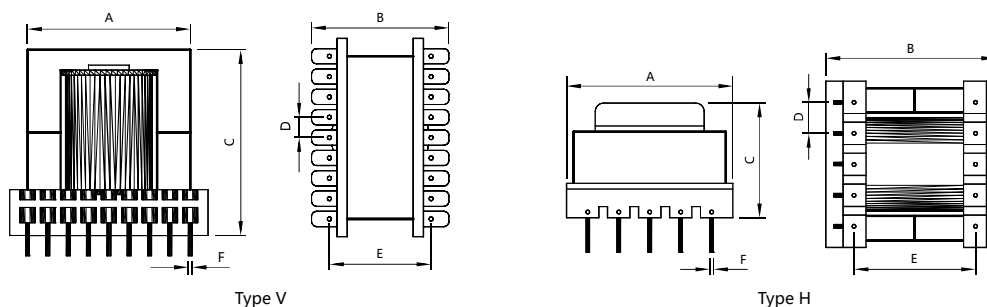

SH-ETD SERIES SWITCHING POWER TRANSFORMER



FEATURES

Center section of the core is round
easily design high-powerswitch transformers
Low leakage

Bulk packaging is standard
Custom design available

Drive transformers
Main transformers
Smoothing chokes
General purpose use



Additional information:
We reserve the right to make technical changes or modify the contents of this document without prior notice.

SHARE Ltd. Does not accept any responsibility what so ever for potential errors or possible lack of information in this document.

We can offer that even custom-made transformers will be covered by approvals from UL, CSA, KEMA, etc., but we will be happy to assist you in implementing them. New approvals may be required.

Part Number	Type	No. of Terminal pins	Dimensions(mm)						Max. output (VA)
			Max A	Max B	Max C	±0.3 D	±0.5 E	±0.1 F	
SH-ETD 24-A	V	12	36.5	25.0	38.0	5.08	17.8	1.1	110
SH-ETD 29-A	H	14	36.0	36.0	25.5	5.0	25.6	0.8	170
SH-ETD 29-B	H	13	37.0	37.0	27.0	5.0	25.8	0.8	170
SH-ETD 29-C	V	12	42.0	24.5	43.0	5.08	20.32	0.8	170
SH-ETD 34-A	V	12	34.5	30.0	37.0	5.0	25.5	1.0	270
SH-ETD 34-B	H	14	41.0	41.0	27.0	5.0	25.5	2.0	270
SH-ETD 34-C	V	14	39.0	28.0	45.0	5.0	22.9	1.0	270
SH-ETD 39-A	V	16	46.0	30.5	49.6	5.0	25.4	1.0	380
SH-ETD 39-B	H	16	45.0	45.0	36.0	5.0	30.2	1.0	380
SH-ETD 44-A	H	18	50.0	51.0	40.0	5.0	35.8	1.0	520
SH-ETD 44-B	V	18	46.0	33.0	51.0	5.0	27.5	1.0	520
SH-ETD 49-A	V	22	55.0	37.0	55.0	5.0	27.5	1.0	680
SH-ETD 49-B	H	20	56.0	55.0	41.0	5.0	40.4	1.0	680
SH-ETD 54-A	H	22	61.0	60.0	47.0	5.0	44.8	1.0	750
SH-ETD 59-A	H	24	68.0	68.0	52.5	5.0	51.0	1.0	900

Note: The output power is only for forward model and the frequency at 100kHz

MECHANICAL DRAWING (mm)

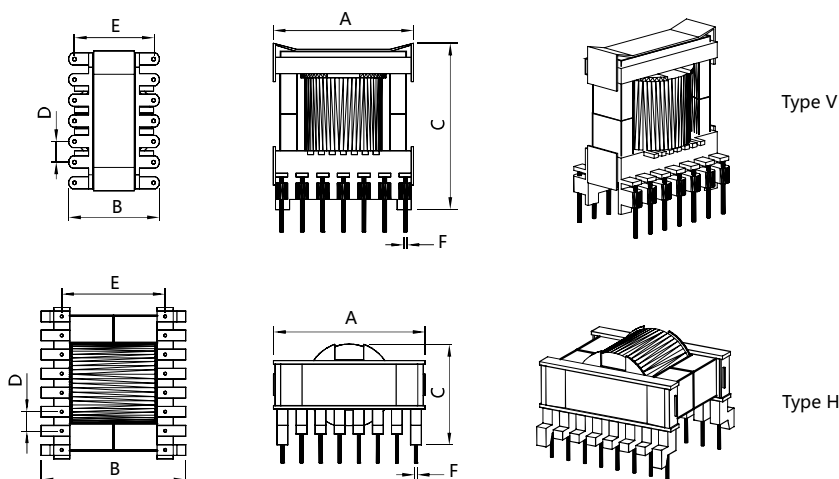

SH-PQ SERIES SWITCHING POWER TRANSFORMER

FEATURES



Design in the flattest shape
Applied in the power: (50W-1kW)100kHz
Cut down installation cubage with multi-pluge and boobins, easily wire connection to meet the request
Low leakage

Bulk packaging is standard
Custom design available

Drive transformers
Main transformers
Smoothing chokes
Switching power supplies
AC-DC, DC-DC converters



Additional information:
We reserve the right to make technical changes or modify the contents of this document without prior notice.
SHARE Ltd. Does not accept any responsibility what so ever for potential errors or possible lack of information in this document.
We can offer that even custom-made transformers will be covered by approvals from UL, CSA, KEMA, etc., but we will be happy to assist you in implementing them.
New approvals may be required.

Part Number	Type	No. of Terminal pins	Max A	Max B	Dimensions(mm)				Max. output (VA)
					Max C	±0.3 D	±0.5 F	±0.1 G	
SH-PQ 2020-A	V	14(6+8)	24.0	24.0	3.8/2.5	5.1	20.3	0.6	92
SH-PQ 2620-A	V	12	28.0	32.0	3.8	7.6	25.4	0.6	170
SH-PQ 2620-B	V	12	28.0	32.0	3.8	7.6	25.4	0.6	170
SH-PQ 2625-A	V	12	28.5	31.0	3.8	7.5	25.5	0.7	195
SH-PQ 3220-A	V	12	33.0	35.0	5.0	7.5	30.0	0.8	232
SH-PQ 3220-B	V	12	33.0	36.0	5.1	7.6	30.5	0.8	232
SH-PQ 3225-A	V	12	35.5	35.0	5.0	7.4	30.0	0.8	280
SH-PQ 3230-A	V	12	33.0	36.0	5.05	7.6	30.3	0.8	331
SH-PQ 3535-A	V	12	37.0	41.0	5.0	10.0	35.0	0.8	452
SH-PQ 4040-A	V	12	41.0	44.0	5.0	15.1	38.0	0.8	596
SH-PQ 5050-A	V	12	52.0	53.0	7.62	15.24	45.72	1.2	1045

Note: The output power is only for forward model and the frequency at 100kHz

MECHANICAL DRAWING (mm)

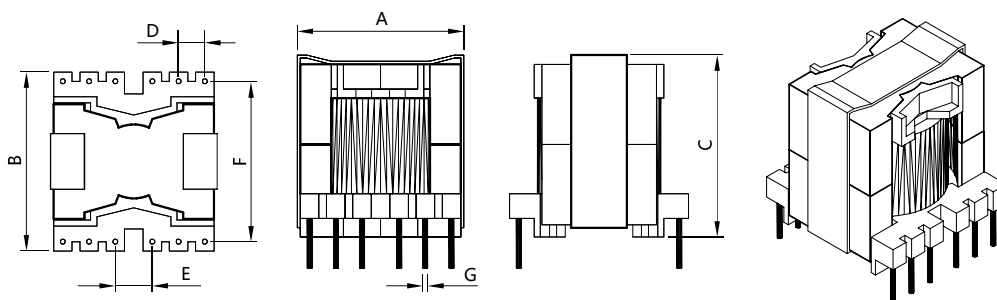

Type V

SH-EFD SERIES SWITCHING POWER TRANSFORMER

FEATURES

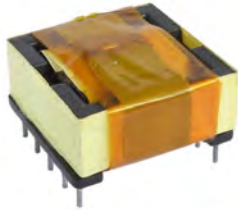

Horizontal installation
Multi out-put applied
in denseness installation

Bulk packaging is standard
Custom design available

Drive transformers
Main transformers
Smoothing chokes
General purpose use
Switching power supplies
AC-DC, DC-DC converters



Additional information:

We reserve the right to make technical changes or modify the contents of this document without prior notice.

SHARE Ltd. Does not accept any responsibility what so ever for potential errors or possible lack of information in this document.

We can offer that even custom-made transformers will be covered by approvals from UL, CSA, KEMA, etc., but we will be happy to assist you in implementing them. New approvals may be required.

Part Number	Type	No. of Terminal pins	Max A	Max B	Max C	±0.3 D	±0.5 E	±0.1 F	Max. output (VA)
FATEFD 15-A	H	8	17	18	9.5	3.7	13.7	0.6	5
FATEFD 15-B	H	8	17	18	9.5	3.75	13.75	0.6	5
FATEFD 15-C	H	8	17	18	9.5	3.8	13.7	0.6	5
FATEFD 20-A	H	8	22	23	11.0	5.0	17.5	0.6	18
FATEFD 20-B	H	9	22	23	11.0	5.0	17.5	0.6	18
FATEFD 20-C	H	10	22	26	15.0	3.8	23.8	0.6	18
FATEFD 25-A	H	10	27	28	13.0	5.0	22.45	0.8	45
FATEFD 25-B	H	10	27	28	15.0	5.0	22.5	0.8	45
FATEFD 30-A	H	12	32	33	14.0	5.0	27.4	0.8	70
FATEFD 30-B	H	12	32	36	18.0	5.0	30.0	0.8	70
FATEFD 30-C	H	12	32	37	14.0	5.0	32.0	0.8	70

Note: The output power is only for forward model and the frequency at 100kHz

MECHANICAL DRAWING (mm)

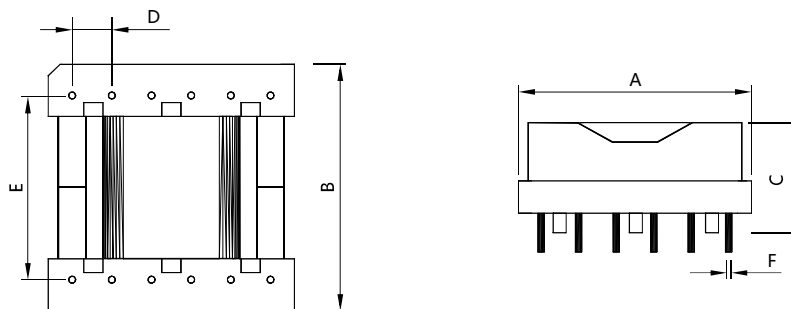

Type H

SCS 74001, 74002 SERIES 1-6W E16 - SINGLE OUTPUT FLYBACK TRANSFORMER

FEATURES

Primary / Secondary Insulation $\geq 4000V$
 Primary Auxiliary Insulation $\geq 1500V$
 Creepage distances
 Primary/secondary $\geq 6mm$

Bulk packaging is standard
 Custom design available

AC-DC converters
 DC-DC converters
 Switch Power supplies
 SMPS: Flyback, Forward and Push-pull
 SMPS: Half Bridge and Full Bridge



TECHNICAL INFORMATION

- Ambient temperature $< 60^{\circ}C$
- Construction confirms to CEI950, CEI335, CEI61558 for reinforced insulation
- Exclusively uses UL94-V0 listed materials

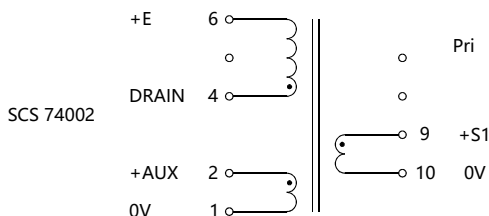
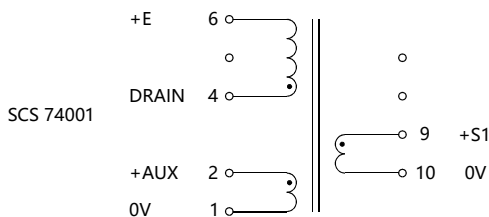

Note: PIN 3 Removed, PCB Drilling Diameter = 1.1mm

ELECTRICAL CHARACTERISTICS AT 25°C

Control IC Manufacturer	Control IC P/N	Input voltage	Power	Frequency
Infineon	TDA16831	185-265Vrms	6 W	100 kHz
Motorola	MC33369	85-265Vrms	6 W	100 kHz
Power Integrations	TOP242P	85-265Vrms	6 W	132 kHz
ST Microelectronics	VIPer20	85-265Vrms	6 W	70 kHz
ST Microelectronics	VIPer20	85-265Vrms	3 W	40 kHz

SIZE E16 - SINGLE OUTPUT : 5 or 12V - FLYBACK TRANSFORMER

Part Number	Output Power max	Pins	Turns	Windings		Current max	Inductance (+/-10%)
				Voltage			
SCS 74001	6W	Pri	4-6	138	60-120(VOR)	0.35 Apeak	3000μH
		Aux	2-1	16	8-16Vdc	0.1 Adc	
		S1	9-10	8	3-6Vdc	1.2 Adc	
SCS 74002	6W	Pri	4-6	150	60-120(VOR)	0.38 Apeak	3000μH
		Aux	2-1	22	8.5-17Vdc	0.1 Adc	
		S1	9-10	24	9-18Vdc	0.5 Adc	

Note: Regulation with auxiliary winding

PHYSICAL CHARACTERISTICS(unit:mm)

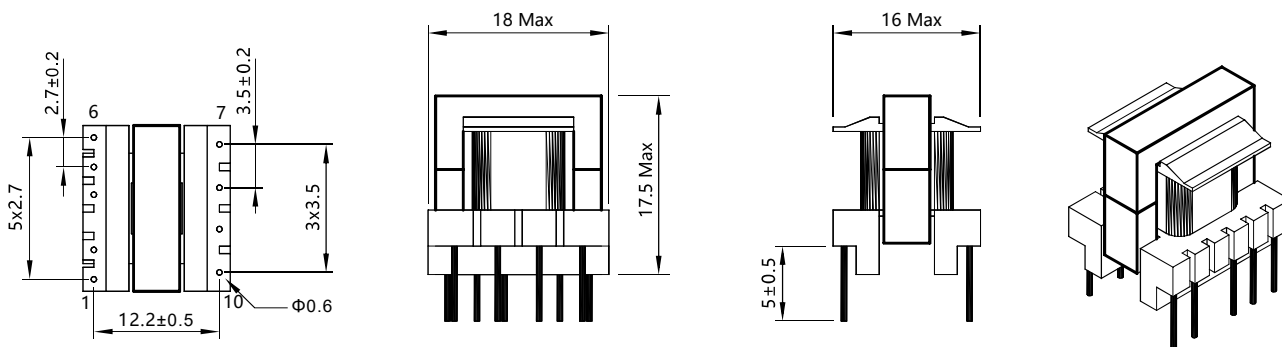

SCS 74000, 74003 SERIES 1-6W E16 -2 OUTPUT FLYBACK TRANSFORMER



FEATURES

- Primary / Secondary Insulation $\geq 4000V$
- Primary Auxiliary Insulation $\geq 1500V$
- Creepage distances
- Primary/secondary $\geq 6mm$
- Bulk packaging is standard
- Custom design available
- AC-DC converters
- DC-DC converters
- Switch Power supplies
- SMPS: Flyback, Forward and Push-pull
- SMPS: Half Bridge and Full Bridge



Additional information:
We reserve the right to make technical changes or modify the contents of this document without prior notice.
SHARE Ltd. Does not accept any responsibility what so ever for potential errors or possible lack of information in this document.
We can offer that even custom-made transformers will be covered by approvals from UL, CSA, KEMA, etc., but we will be happy to assist you in implementing them.
New approvals may be required.

TECHNICAL INFORMATION

- Ambient temperature $< 70^{\circ}C$
- Construction confirms to CEI950, CEI335, CEI61558 for reinforced insulation
- Exclusively uses UL94-V0 listed materials

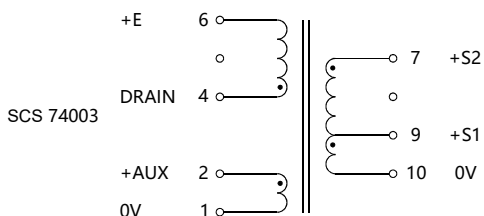
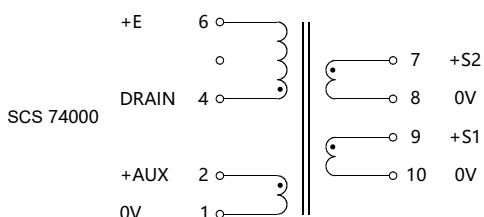

Note: PIN 3 Removed, PCB Drilling Diameter = 1.1mm

ELECTRICAL CHARACTERISTICS AT 25°C

74000 E16 5w 5/12V

Control IC Manufacturer	Control IC P/N	Input voltage	Power	Frequency
Power Integrations	TOP242P	85-265Vrms	5 W	132 kHz
ST Microelectronics	VIPer20	85-265Vrms	4 W	70 kHz

74000 E16 5w 5/12V

Control IC Manufacturer	Control IC P/N	Input voltage	Power	Frequency
Infineon	TDA16831	185-265Vrms	6 W	100 kHz
Motorola	MC33369	85-265Vrms	6 W	100 kHz
Power Integrations	TOP242P	85-265Vrms	5 W	132 kHz
ST Microelectronics	VIPer20	85-265Vrms	6 W	70 kHz
ST Microelectronics	VIPer20	85-265Vrms	3 W	40 kHz

SIZE E16 - SINGLE OUTPUT : 5 or 12V - FLYBACK TRANSFORMER

Part Number	Output Power max	Pins	Windings			Inductance (+/-10%)
			Turns	Voltage	Current max	
SCS 74000	5W	Pri	4-6	138	62-130(VOR)	0.27Apeak
		Aux	2-1	16	7-14Vdc	0.1Adc
		S1	9-10	8	3.3-7Vdc	1.2Adc
		S2	7-8	19	8-17Vdc	0.4Adc
SCS 74003	5W	Pri	4-6	120	55-115(VOR)	0.3Apeak
		Aux	2-1	17	8-16Vdc	0.1Adc
		S1	9-10	5	2-4Vdc	0.8Adc
		S2	7-10	7	3-6Vdc	1.2Adc

Note: Regulation with auxiliary winding

PHYSICAL CHARACTERISTICS(unit:mm)

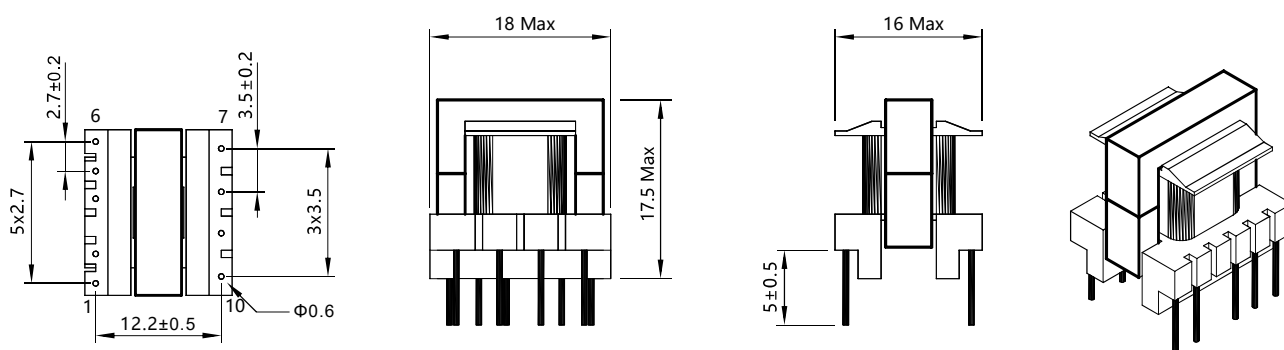

SCS 74090,74091 SERIES 1-9W E16 -SINGLE OUTPUT FLYBACK TRANSFORMERS



FEATURES

Primary / Secondary Insulation $\geq 4000V$
 Creepage distances
 Primary/secondary $\geq 6mm$

Bulk packaging is standard
 Custom design available

AC-DC converters
 DC-DC converters
 Switch Power supplies
 SMPS: Flyback, Forward and Push-pull
 SMPS: Half Bridge and Full Bridge



Additional information:

We reserve the right to make technical changes or modify the contents of this document without prior notice.

SHARE Ltd. Does not accept any responsibility what so ever for potential errors or possible lack of information in this document.

We can offer that even custom-made transformers will be covered by approvals from UL, CSA, KEMA, etc., but we will be happy to assist you in implementing them. New approvals may be required.

TECHNICAL INFORMATION

- Ambient temperature $< 85^{\circ}C$
- Construction confirms to CEI950, CEI335, CEI61558 for reinforced insulation
- Exclusively uses UL94-V0 listed materials

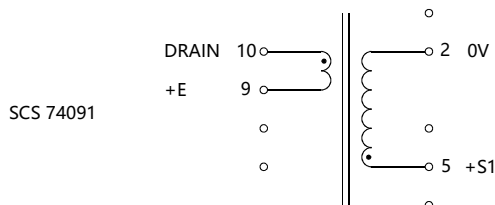
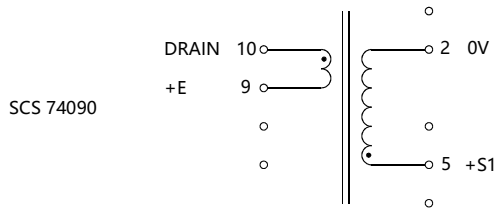

ELECTRICAL CHARACTERISTICS AT 25°C

74090

Control IC Manufacturer	Control IC P/N	Input voltage	Power	Frequency
Power Integrations	TNY254	85-265Vrms	1.5W	44kHz

74091

Control IC Manufacturer	Control IC P/N	Input voltage	Power	Frequency
Power Integrations	TNY254	85-265Vrms	1.5W	44kHz

SIZE E16 - SINGLE OUTPUT : 5 or 12V - FLYBACK TRANSFORMER

Part Number	Output Power max	Windings					
		Pins	Turns	Voltage	Current max	Inductance ($\pm 10\%$)	
SCS 74090	1.5W	Pri	10-9	228	50-95(VOR)	0.28 Apeak	6000 μ H
		S1	5-2	16	3.3-6Vdc	0.4 Adc	
SCS 74091	1.5W	Pri	10-9	228	65-130(VOR)	0.28 Apeak	6000 μ H
		S1	5-2	28	7.5-15Vdc	0.2 Adc	

Note: PIN 3 Removed, PCB Drilling Diameter = 1.1mm

Note: Regulation with auxiliary winding

PHYSICAL CHARACTERISTICS(unit:mm)

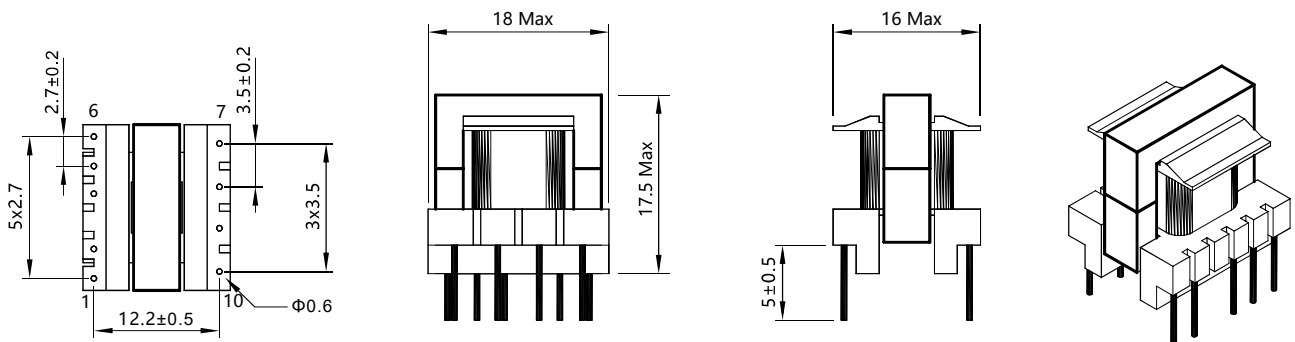

SCS 74092,74093 SERIES 1-9W E16 -SINGLE OUTPUT FLYBACK TRANSFORMERS



FEATURES

- Primary / Secondary Insulation $\geq 4000V$
- Creepage distances
- Primary/secondary $\geq 6mm$
- Bulk packaging is standard
- Custom design available
- AC-DC converters
- DC-DC converters
- Switch Power supplies
- SMPS: Flyback, Forward and Push-pull
- SMPS: Half Bridge and Full Bridge



Additional information:

We reserve the right to make technical changes or modify the contents of this document without prior notice.

SHARE Ltd. Does not accept any responsibility what so ever for potential errors or possible lack of information in this document.

We can offer that even custom-made transformers will be covered by approvals from UL, CSA, KEMA, etc., but we will be happy to assist you in implementing them. New approvals may be required.

TECHNICAL INFORMATION

- Ambient temperature $< 70^{\circ}C$
- Construction confirms to CEI950, CEI335, CEI61558 for reinforced insulation
- Exclusively uses UL94-V0 listed materials

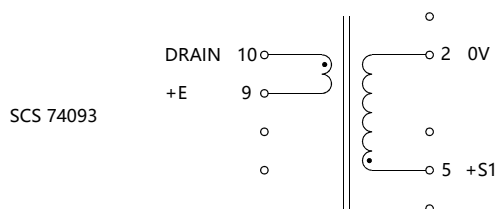
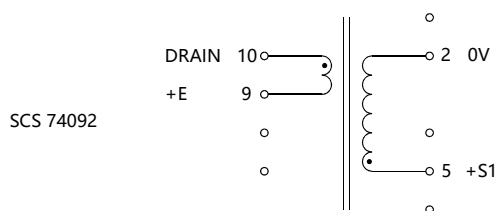

Note: PIN 3 Removed, PCB Drilling Diameter = 1.1mm

ELECTRICAL CHARACTERISTICS AT 25°C

74092				
Control IC Manufacturer	Control IC P/N	Input voltage	Power	Frequency
Power Integrations	TNY254	85-265Vrms	3.1W	44kHz

74093				
Control IC Manufacturer	Control IC P/N	Input voltage	Power	Frequency
Power Integrations	TNY254	85-265Vrms	3.1W	44kHz

SIZE E16 - SINGLE OUTPUT : 5 or 12V - FLYBACK TRANSFORMER

Part Number	Output Power max	Windings				
		Pins	Turns	Voltage	Current max	Inductance (+/-10%)
SCS 74092	3.1W	Pri 10-9	191	55-100(VOR)	0.34Apeak	4200 μ H
		S1 5-2	13	3.3-6Vdc	0.9Aadc	
SCS 74093	3.1W	Pri 10-9	191	65-125(VOR)	0.34Apeak	4200 μ H
		S1 5-2	24	7.5-15Vdc	0.4Aadc	

Note: Regulation with auxiliary winding

PHYSICAL CHARACTERISTICS(unit:mm)

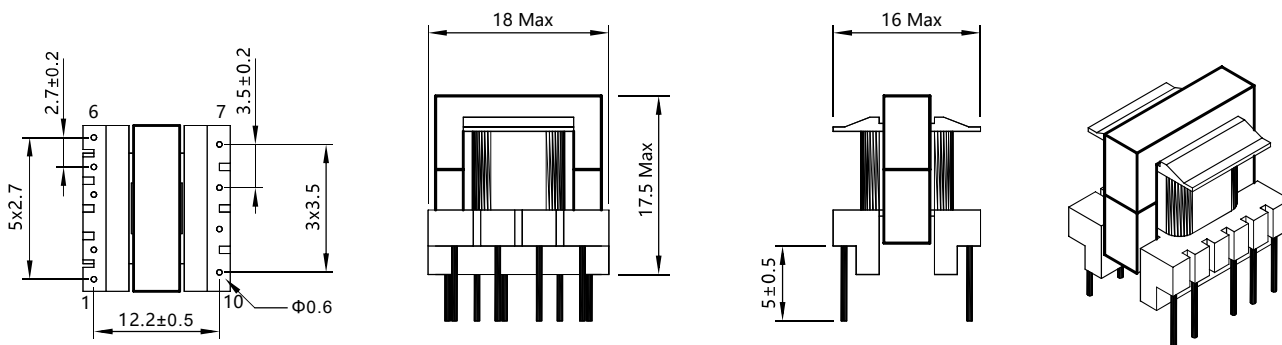

SCS 74094, 74095 SERIES 1-9W E16 -SINGLE OUTPUT FLYBACK TRANSFORMERS

FEATURES

Primary / Secondary Insulation $\geq 4000V$
 Creepage distances
 Primary/secondary $\geq 6mm$

Bulk packaging is standard
 Custom design available

AC-DC converters
 DC-DC converters
 Switch Power supplies
 SMPS: Flyback, Forward and Push-pull
 SMPS: Half Bridge and Full Bridge



Additional information:
 We reserve the right to make technical changes or modify the contents of this document without prior notice.
 SHARE Ltd. Does not accept any responsibility what so ever for potential errors or possible lack of information in this document.
 We can offer that even custom-made transformers will be covered by approvals from UL, CSA, KEMA, etc., but we will be happy to assist you in implementing them.
 New approvals may be required.



TECHNICAL INFORMATION

- Ambient temperature $< 60^{\circ}C$
- Construction confirms to CEI950, CEI335, CEI61558 for reinforced insulation
- Exclusively uses UL94-V0 listed materials

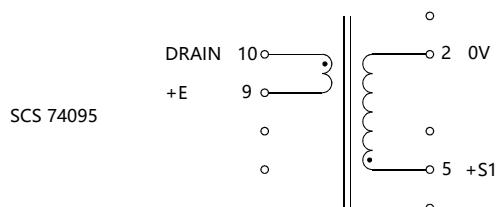
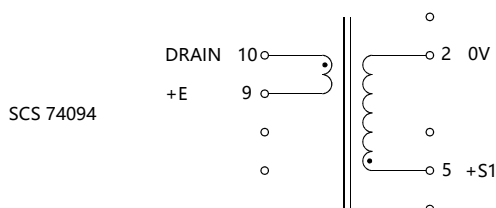

ELECTRICAL CHARACTERISTICS AT 25°C

74094				
Control IC Manufacturer	Control IC P/N	Input voltage	Power	Frequency
Power Integrations	TNY255	85-265Vrms	4.2 w	44 kHz
Power Integrations	TNY264	85-265Vrms	5 w	132 kHz
Power Integrations	TNY266	85-265Vrms	9 w	132 kHz

74095				
Control IC Manufacturer	Control IC P/N	Input voltage	Power	Frequency
Power Integrations	TNY255	85-265Vrms	5 w	44 kHz
Power Integrations	TNY264	85-265Vrms	5 w	132 kHz
Power Integrations	TNY266	85-265Vrms	9 w	132 kHz

SIZE E16 - SINGLE OUTPUT : 5 or 12V TRANSFORMER FOR TINYSWITCH

Part Number	Output Power max	Pins	Windings			Current max	Inductance (+/-10%)
			Turns	Voltage			
SCS 74094	9W	Pri	10-9	135	55-100(VOR)	0.48Apeak	2100μH
		S1	5-2	9	3.3-6Vdc		
SCS 74095	9W	Pri	10-9	135	65-125(VOR)	0.48Apeak	2100μH
		S1	5-2	17	7.5-15Vdc		

Note: PIN 3 Removed, PCB Drilling Diameter = 1.1mm

Note: Regulation with auxiliary winding

PHYSICAL CHARACTERISTICS(unit:mm)

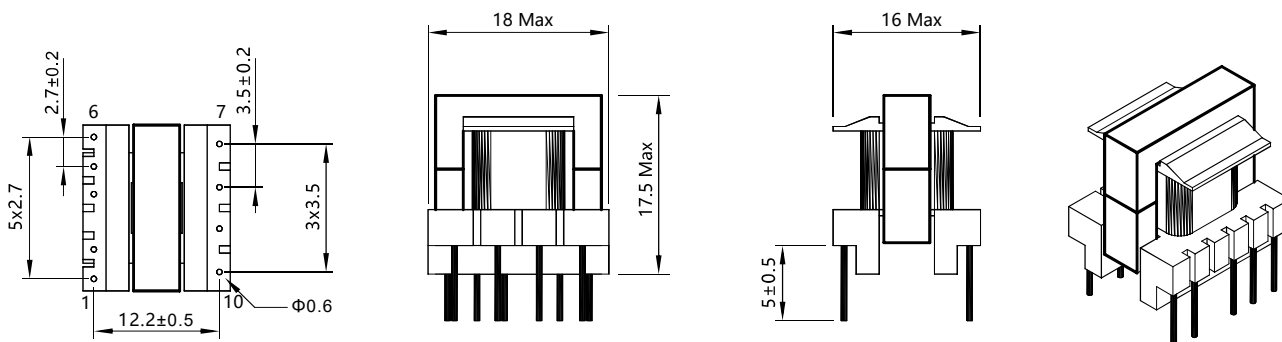

SCS 74010 SERIES 6-12W E16 -2 OUTPUT FLYBACK TRANSFORMERS



FEATURES

Primary / Secondary Insulation $\geq 4000V$
 Primary Auxiliary Insulation $\geq 1500V$
 Creepage distances
 Primary/secondary $\geq 6mm$

Bulk packaging is standard
 Custom design available

AC-DC converters
 DC-DC converters
 Switch Power supplies
 SMPS: Flyback, Forward and Push-pull
 SMPS: Half Bridge and Full Bridge



Additional information:
 We reserve the right to make technical changes or modify the contents of this document without prior notice.
 SHARE Ltd. Does not accept any responsibility what so ever for potential errors or possible lack of information in this document.
 We can offer that even custom-made transformers will be covered by approvals from UL, CSA, KEMA, etc., but we will be happy to assist you in implementing them.
 New approvals may be required.

TECHNICAL INFORMATION

- Ambient temperature $< 60^{\circ}C$
- Construction confirms to CEI950, CEI335, CEI61558 for reinforced insulation
- Exclusively uses UL94-V0 listed materials

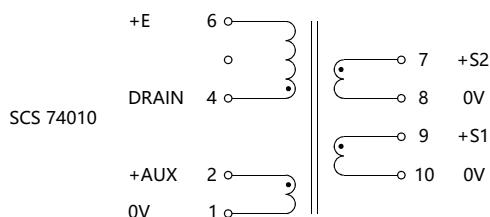

Note: PIN 3 Removed, PCB Drilling Diameter = 1.1mm

ELECTRICAL CHARACTERISTICS AT 25°C

Control IC Manufacturer	Control IC P/N	Input voltage	Power	Frequency
Fairchild	KA5H0165RN	185-265Vrms	10 w	100 kHz
Fairchild	KA5L0165R	85-265Vrms	7 w	50 kHz
Infineon	TDA16831	92-265Vrms	7.5 w	100 kHz
Infineon	TDA16831	185-265Vrms	10 w	100 kHz
Motorola	MC33369	85-265Vrms	8 w	100 kHz
Motorola	MC33369	185-265Vrms	10 w	100 kHz
Power Integrations	TNY267	185-265Vrms	12 w	132 kHz
Power Integrations	TOP242P	85-265Vrms	10 w	132 kHz
Power Integrations	TOP242P	185-265Vrms	12 w	132 kHz
Power Integrations	TOP242P	85-265Vrms	10 w	132 kHz
ST Microelectronics	VIPer20	85-265Vrms	8 w	70 kHz
ST Microelectronics	VIPer20	185-265Vrms	10 w	70 kHz

SIZE E16 - 2 OUTPUTS : 5 & 12V - FLYBACK TRANSFORMER

Part Number	Output Power max	Windings					
		Pins	Turns	Voltage	Current max	Inductance (+/-10%)	
SCS 74010	12W	Pri	4-6	120	60-125(VOR)	0.55Apeak	1660μH
		Aux	2-1	14	7-14Vdc	0.1 Adc	
		S1	9-10	7	3.3-7Vdc	2 Adc	
		S2	7-8	17	8-17Vdc	1 Adc	

Note: Regulation with auxiliary winding

PHYSICAL CHARACTERISTICS(unit:mm)

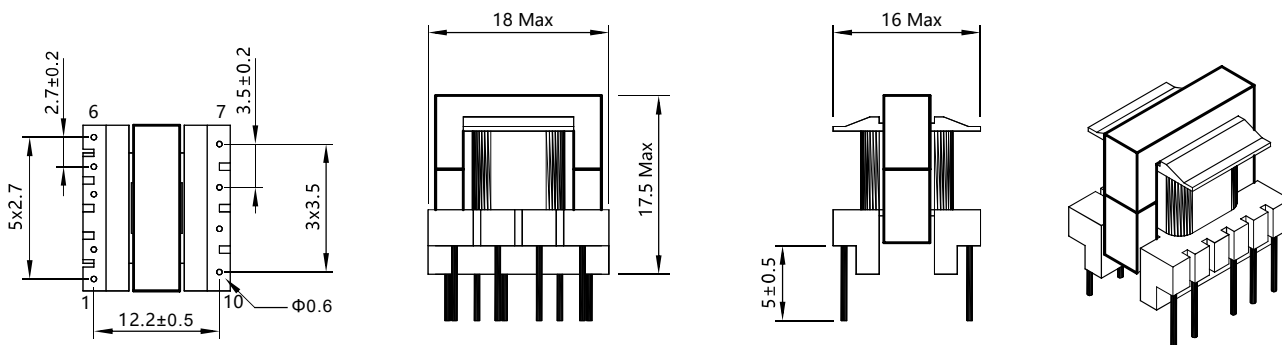

SCS 74014 SERIES 6-12W E16 -2 OUTPUT FLYBACK TRANSFORMERS

FEATURES

Primary / Secondary Insulation $\geq 4000V$
 Creepage distances
 Primary/secondary $\geq 6mm$

Bulk packaging is standard
 Custom design available

AC-DC converters
 DC-DC converters
 Switch Power supplies
 SMPS: Flyback, Forward and Push-pull
 SMPS: Half Bridge and Full Bridge



Additional information:
 We reserve the right to make technical changes or modify the contents of this document without prior notice.
 SHARE Ltd. Does not accept any responsibility what so ever for potential errors or possible lack of information in this document.
 We can offer that even custom-made transformers will be covered by approvals from UL, CSA, KEMA, etc., but we will be happy to assist you in implementing them.
 New approvals may be required.



TECHNICAL INFORMATION

- Ambient temperature $< 50^{\circ}C$
- Construction confirms to CEI950, CEI335, CEI61558 for reinforced insulation
- Exclusively uses UL94-VO listed materials
- Typical outputs : + 24V 0.5A with S1 - S2 in parallel
- + 48V 0.25A with S1 - S2 in series (8-9 connected)
- + 15V / - 15V 0.4A with pins 8-9 connected to 0V

ELECTRICAL CHARACTERISTICS AT 25°C

Control IC Manufacturer	Control IC P/N	Input voltage	Power	Frequency
Power Integrations	TNY266	185-265Vrms	12 w	132 kHz
Power Integrations	TNY266	85-265Vrms	8 w	132 kHz
Power Integrations	TNY242P	185-265Vrms	12 w	132 kHz
Power Integrations	TNY242P	85-265Vrms	8 w	132 kHz

SIZE E16 - 2 OUTPUTS : 5 & 12V - FLYBACK TRANSFORMER

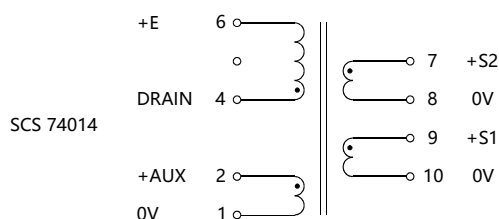

Part Number	Output Power max	Windings			Current max	Inductance (+/-10%)
		Pins	Turns	Voltage		
SCS 74014	12W	Pri	4-6	120	70-140(VOR)	0.5 Apeak
		Aux	2-1	17	9-18 Vdc	0.2 Adc
		S1	9-10	27	15-30 Vdc	0.4 Adc
		S2	7-8	27	15-30 Vdc	0.4 Adc

Note: PIN 3 Removed, PCB Drilling Diameter = 1.1mm

Note: Regulation with auxiliary winding

PHYSICAL CHARACTERISTICS(unit:mm)

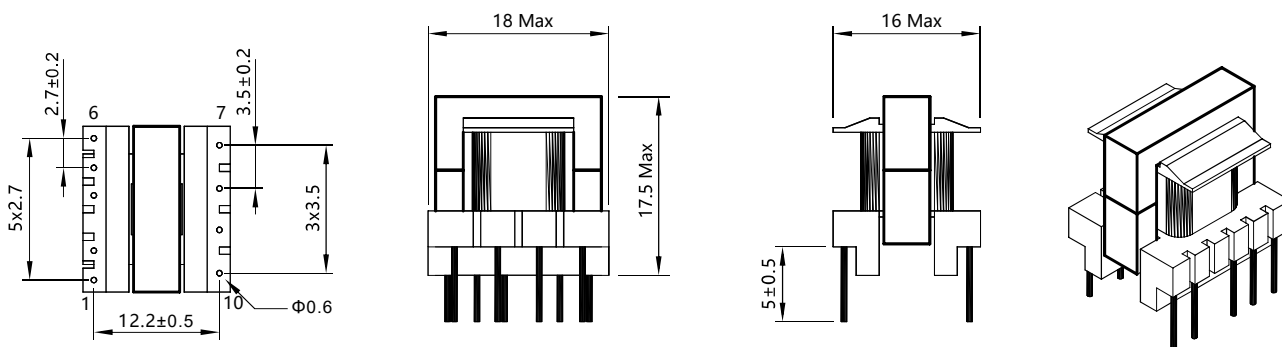

SCS 74015 SERIES 6-12W E16 -3 OUTPUT FLYBACK TRANSFORMERS



FEATURES

Primary / Secondary Insulation $\geq 4000V$
 Creepage distances
 Primary/secondary $\geq 6mm$

Bulk packaging is standard
 Custom design available

AC-DC converters
 DC-DC converters
 Switch Power supplies
 SMPS: Flyback, Forward and Push-pull
 SMPS: Half Bridge and Full Bridge



Additional information:

We reserve the right to make technical changes or modify the contents of this document without prior notice.

SHARE Ltd. Does not accept any responsibility what so ever for potential errors or possible lack of information in this document.

We can offer that even custom-made transformers will be covered by approvals from UL, CSA, KEMA, etc., but we will be happy to assist you in implementing them. New approvals may be required.

TECHNICAL INFORMATION

- Ambient temperature $< 50^{\circ}C$
- Construction confirms to CEI950, CEI335, CEI61558 for reinforced insulation
- Exclusively uses UL94-VO listed materials

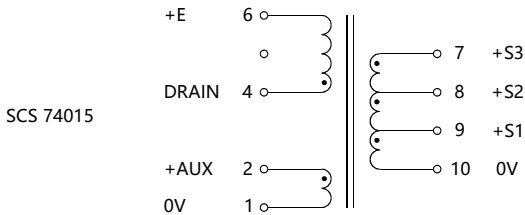

Note: PIN 3 Removed, PCB Drilling Diameter = 1.1mm

ELECTRICAL CHARACTERISTICS AT 25°C

Control IC Manufacturer	Control IC P/N	Input voltage	Power	Frequency
Power Integrations	TNY266	185-265Vrms	10 w	132 kHz
Power Integrations	TNY266	85-265Vrms	8 w	132 kHz
Power Integrations	TNY242P	185-265Vrms	12 w	132 kHz
Power Integrations	TNY242P	85-265Vrms	9 w	132 kHz

SIZE E16 - 3 OUTPUTS : 5 & 12V - FLYBACK TRANSFORMER

Part Number	Output Power max	Pins	Turns	Windings			
				Voltage	Current max	Inductance (+/-10%)	
SCS 74015	12W	Pri	4-6	120	110(VOR)	0.5 Apeak	
		Aux	2-1	14	12 Vdc	0.2 Adc	
		S1	9-10	6	5 Vdc	1.5 Adc	1800μH
		S2	8-10	17	15 Vdc	0.6 Adc	
		S3	7-10	27	24 Vdc	0.4 Adc	

Note: Regulation with auxiliary winding

PHYSICAL CHARACTERISTICS(unit:mm)

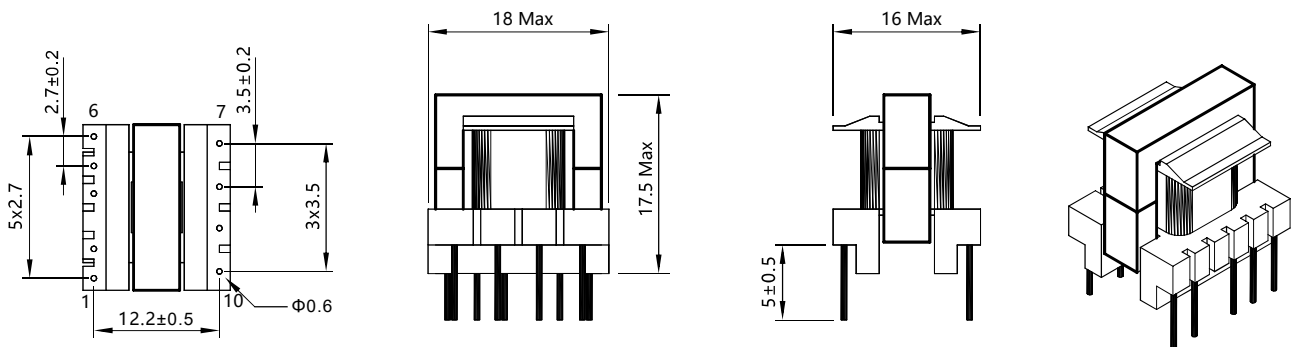

SCS 74020 SERIES 10-18W EL19 -2 OUTPUT FLYBACK TRANSFORMERS

FEATURES

Primary / Secondary Insulation $\geq 4000V$
 Creepage distances
 Primary/secondary $\geq 6mm$

Bulk packaging is standard
 Custom design available

AC-DC converters
 DC-DC converters
 Switch Power supplies
 FAPS: Flyback, Forward and Push-pull
 FAPS: Half Bridge and Full Bridge



Additional information:

We reserve the right to make technical changes or modify the contents of this document without prior notice.

SHARE Ltd. Does not accept any responsibility what so ever for potential errors or possible lack of information in this document.

We can offer that even custom-made transformers will be covered by approvals from UL, CSA, KEMA, etc., but we will be happy to assist you in implementing them. New approvals may be required.



TECHNICAL INFORMATION

- Ambient temperature $< 50^{\circ}C$
- Construction confirms to CEI950, CEI335, CEI61558 for reinforced insulation
- Exclusively uses UL94-VO listed materials

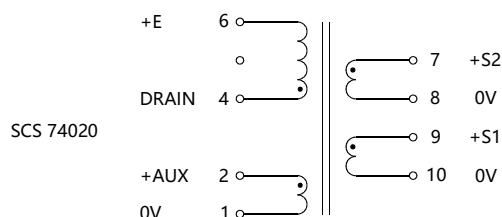

ELECTRICAL CHARACTERISTICS AT 25°C

Control IC Manufacturer	Control IC P/N	Input voltage	Power	Frequency
Power Integrations	TNY268	185-265Vrms	18 w	132 kHz
Power Integrations	TOP243P	185-265Vrms	18 w	132 kHz
Power Integrations	TOP243P	85-265Vrms	12 w	132 kHz
ST Microelectronics	VIPer20	85-265Vrms	10 w	100 kHz
ST Microelectronics	VIPer20	185-265Vrms	12 w	100 kHz
ST Microelectronics	VIPer50	185-265Vrms	16 w	100 kHz
Motorola	MC33370	185-265Vrms	16 w	100 kHz
Infineon	TDA16832	185-265Vrms	16 w	70 kHz

SIZE EL19 - 2 OUTPUTS : 5 & 12V - FLYBACK TRANSFORMER

Part Number	Output Power max	Pins	Turns	Windings			
				Voltage	Current max	Inductance (+/-10%)	
SCS 74020	18W	Pri	4-6	108	65-130(VOR)	0.8 Apeak	1250 μ H
		Aux	2-1	12	7-14 Vdc	0.1 Adc	
		S1	9-10	6	3.3-7 Vdc	3 Adc	
		S2	7-8	14	8-16.5 Vdc	1.4 Adc	

Note: Regulation with auxiliary winding

PHYSICAL CHARACTERISTICS(unit:mm)

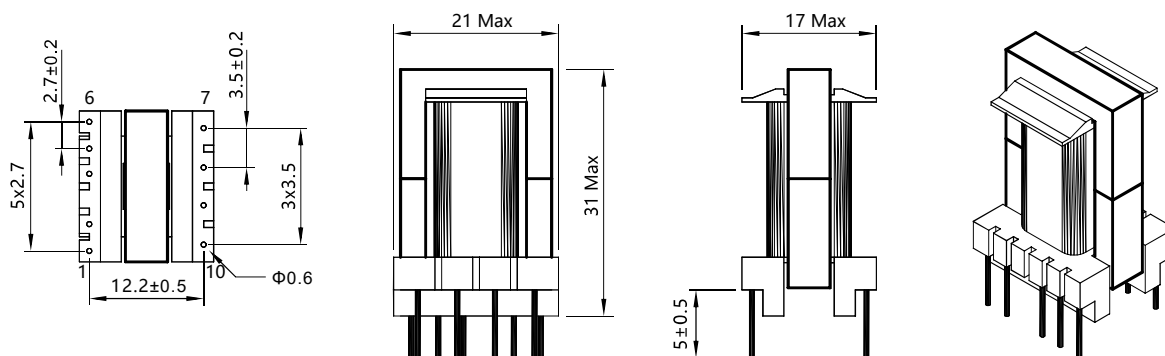

SCS 74021 SERIES 10-18W EL19 -2 OUTPUT FLYBACK TRANSFORMERS



FEATURES

Primary / Secondary Insulation $\geq 4000V$
 Primary Auxiliary Insulation 1500V
 Creepage distances
 Primary/secondary $\geq 6mm$

Bulk packaging is standard
 Custom design available

AC-DC converters
 DC-DC converters
 Switch Power supplies
 FAPS: Flyback, Forward and Push-pull
 FAPS: Half Bridge and Full Bridge



Additional information:
 We reserve the right to make technical changes or modify the contents of this document without prior notice.
 SHARE Ltd. Does not accept any responsibility what so ever for potential errors or possible lack of information in this document.
 We can offer that even custom-made transformers will be covered by approvals from UL, CSA, KEMA, etc., but we will be happy to assist you in implementing them.
 New approvals may be required.

TECHNICAL INFORMATION

- Ambient temperature $< 50^{\circ}C$
- Construction confirms to CEI950, CEI335, CEI61558 for reinforced insulation
- Exclusively uses UL94-VO listed materials

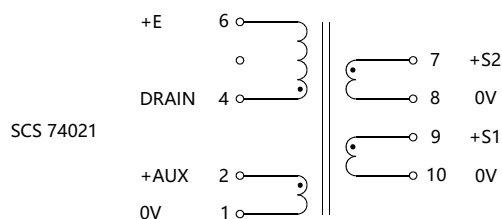

Note: PIN 3 Removed, PCB Drilling Diameter = 1.1mm

ELECTRICAL CHARACTERISTICS AT 25°C

Control IC Manufacturer	Control IC P/N	Input voltage	Power	Frequency
Power Integrations	TOP243Y	185-265Vrms	18 w	132kHz
Power Integrations	TOP243Y	85-265Vrms	12 w	66/132kHz
ST Microelectronics	VIPer50	85-265Vrms	13 w	70kHz
Motorola	MC33370	85-265Vrms	13 w	100kHz
Infineon	TDA16831	92-265Vrms	10 w	100kHz

SIZE EL19 - 2 OUTPUTS : 5 & 12V - FLYBACK TRANSFORMER

Part Number	Output Power max	Windings				
		Pins	Turns	Voltage	Current max	Inductance (+/-10%)
SCS 74021	18W	Pri	4-6	108	65-130(VOR)	1.1 Apeak
		Aux	2-1	12	7-14 Vdc	0.1 Adc
		S1	9-10	6	3.3-7 Vdc	3 Adc
		S2	7-8	14	8-16.5 Vdc	1.4 Adc

Note: Regulation with auxiliary winding

PHYSICAL CHARACTERISTICS(unit:mm)

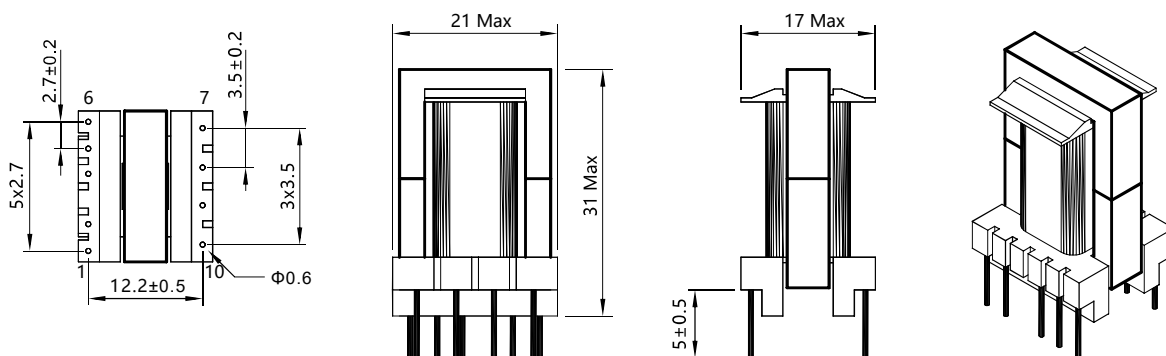

SCS 74023 SERIES 10-18W EL19 -5 OUTPUT FLYBACK TRANSFORMERS



FEATURES

Primary / Secondary Insulation $\geq 4000V$
 Primary Auxiliary Insulation 1500V
 Creepage distances
 Primary/secondary $\geq 6mm$

Bulk packaging is standard
 Custom design available

AC-DC converters
 DC-DC converters
 Switch Power supplies
 FAPS: Flyback, Forward and Push-pull
 FAPS: Half Bridge and Full Bridge



Additional information:
 We reserve the right to make technical changes or modify the contents of this document without prior notice.
 SHARE Ltd. Does not accept any responsibility what so ever for potential errors or possible lack of information in this document.
 We can offer that even custom-made transformers will be covered by approvals from UL, CSA, KEMA, etc., but we will be happy to assist you in implementing them.
 New approvals may be required.

TECHNICAL INFORMATION

- Ambient temperature $< 60^{\circ}C$
- Construction confirms to CEI950, CEI335, CEI61558 for reinforced insulation
- Exclusively uses UL94-VO listed materials

ELECTRICAL CHARACTERISTICS AT 25°C

Control IC Manufacturer	Control IC P/N	Input voltage	Power	Frequency
Power Integrations	TOP243P	185-265Vrms	16 w	132 kHz
Power Integrations	TOP243P	85-265Vrms	12 w	132 kHz

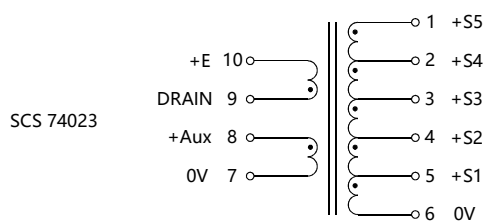

Note: PIN 3 Removed, PCB Drilling Diameter = 1.1mm

SIZE EL19 - 5 OUTPUTS : 3.3/5/12/18/30v - FLYBACK TRANSFORMER

Part Number	Output Power max	Pins	Turns	Windings			
				Voltage	Current max	Inductance (+/-10%)	
SCS 74023	16W	Pri	9-10	120	110 (VOR)	0.85 Apeak	
		Aux	8-7	17	15 Vdc	0.2 Adc	
		S1	5-6	4	3.3 Vdc	2 Adc	
		S2	4-6	6	5 Vdc	Sum S1+S2	1250μH
		S3	3-6	14	12 Vdc	0.8 Adc	
		S4	2-6	20	18 Vdc	0.8 Adc	
		S5	1-6	33	30 Vdc	0.2 Adc	

Note: Regulation with auxiliary winding

PHYSICAL CHARACTERISTICS(unit:mm)

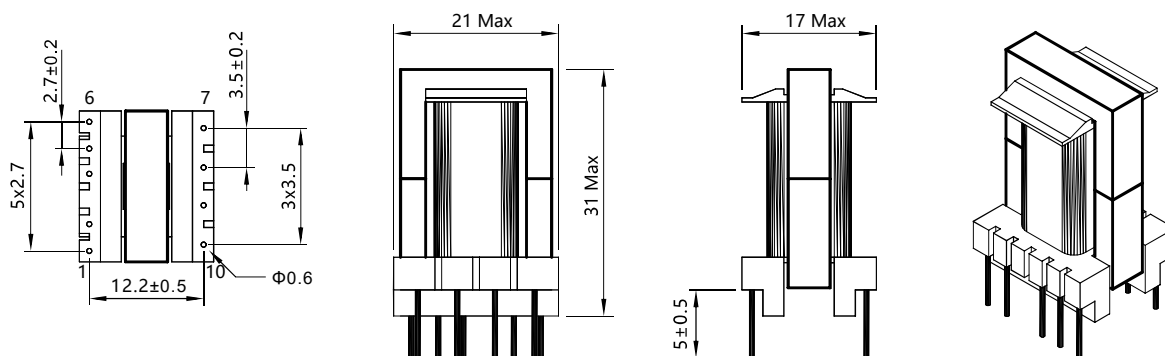

SCS 74080,74082 SERIES 12-24W EF20 -2 OUTPUT FLYBACK TRANSFORMERS

FEATURES

Primary / Secondary Insulation $\geq 4000V$
 Primary Auxiliary Insulation 1500V
 Creepage distances
 Primary/secondary $\geq 8mm$

Bulk packaging is standard
 Custom design available

AC-DC converters
 DC-DC converters
 Switch Power supplies
 FAPS: Flyback, Forward and Push-pull
 FAPS: Half Bridge and Full Bridge



Additional information:
 We reserve the right to make technical changes or modify the contents of this document without prior notice.
 SHARE Ltd. Does not accept any responsibility what so ever for potential errors or possible lack of information in this document.
 We can offer that even custom-made transformers will be covered by approvals from UL, CSA, KEMA, etc., but we will be happy to assist you in implementing them.
 New approvals may be required.



TECHNICAL INFORMATION

- Ambient temperature $< 50^{\circ}C$
- Construction confirms to CEI950, CEI335, CEI61558 for reinforced insulation
- Exclusively uses UL94-VO listed materials

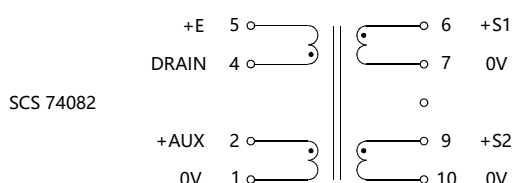
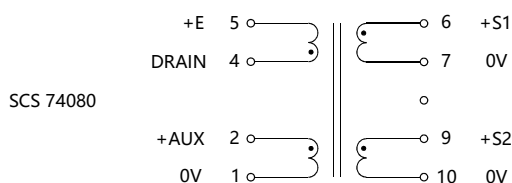

ELECTRICAL CHARACTERISTICS AT 25°C

P/N	Control IC Manufacturer	Control IC P/N	Input voltage	Power	Frequency
SCS 74080	Power Integrations	TOP243P	185-265Vrms	24 w	132 kHz
	Power Integrations	TOP243P	85-265Vrms	15 w	132 kHz
	Power Integrations	TNY268	185-265Vrms	17 w	132 kHz
SCS 74082	Power Integrations	TOP243P	185-265Vrms	20 w	132 kHz
	Power Integrations	TOP243P	85-265Vrms	14 w	132 kHz

SIZE EF20 2 OUTPUTS : 5 /5v or 12/12v - FLYBACK TRANSFORMER

Part Number	Output Power max	Windings				
		Pins	Turns	Voltage	Current max	Inductance (+/-10%)
SCS 74080	24W	Pri	4-5	86	80-135(VOR)	1Apeak
		Aux	2-1	12	11- 8 Vdc	0.3 Adc
		S1	6-7	10	9- 5 Vdc	1.5 Adc
		S2	9-10	10	9-15 Vdc	1.5 Adc
SCS 74082	20W	Pri	4-5	86	30-135(VOR)	0.9Apeak
		Aux	2-1	12	7-18 Vdc	0.3 Adc
		S1	6-7	5	3-7.5 Vdc	2.0 Adc
		S2	9-10	5	3 - 7.5 Vdc	2.0 Adc

Note: PIN 3 Removed, PCB Drilling Diameter = 1.2mm

Note: S1 and S2 can be connected in series or in parallel

PHYSICAL CHARACTERISTICS(unit:mm)

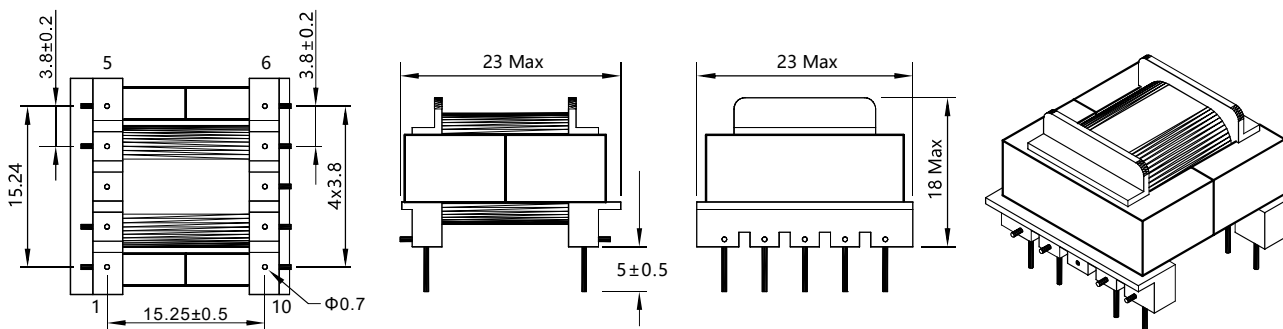

SCS 74081 SERIES 12-24W EF20 -3 OUTPUT FLYBACK TRANSFORMERS

FEATURES

Primary / Secondary Insulation $\geq 4000V$
 Primary Auxiliary Insulation 1500V
 Creepage distances
 Primary/secondary $\geq 8mm$

Bulk packaging is standard
 Custom design available

AC-DC converters
 DC-DC converters
 Switch Power supplies
 FAPS: Flyback, Forward and Push-pull
 FAPS: Half Bridge and Full Bridge



Additional information:
 We reserve the right to make technical changes or modify the contents of this document without prior notice.
 SHARE Ltd. Does not accept any responsibility what so ever for potential errors or possible lack of information in this document.
 We can offer that even custom-made transformers will be covered by approvals from UL, CSA, KEMA, etc., but we will be happy to assist you in implementing them.
 New approvals may be required.



TECHNICAL INFORMATION

- Ambient temperature $< 50^{\circ}C$
- Construction confirms to CEI950, CEI335, CEI61558 for reinforced insulation
- Exclusively uses UL94-VO listed materials

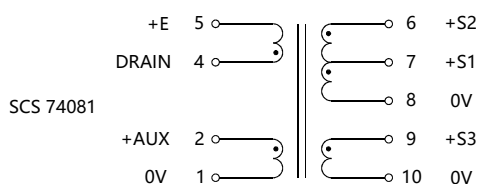

Note: PIN 3 Removed, PCB Drilling Diameter = 1.2mm

ELECTRICAL CHARACTERISTICS AT 25°C

P/N	Control IC Manufacturer	Control IC P/N	Input voltage	Power	Frequency
SCS 74081	Power Integrations	TOP243P	185-265Vrms	20 w	132 kHz
	Power Integrations	TOP243P	85-265Vrms	14 w	132 kHz

SIZE EL20- 3 OUTPUTS : 5/5v or 12/12v - FLYBACK TRANSFORMER

Part Number	Output Power max	Pins	Turns	Windings		
				Voltage	Current max	Inductance (+/-10%)
SCS 74081	20W	Pri	4-5	80	75 (VOR)	0.9 Apeak
		Aux	2-1	17	15 Vdc	0.3 Adc
		S1	7-8	4	3.3 Vdc	3 Adc
	S2	6-8	6	5 Vdc	sum S1+S2	
	S3	9-10	14	12 Vdc	1.3 Adc	
						1100μH

Note: Regulation with auxiliary winding

PHYSICAL CHARACTERISTICS(unit:mm)

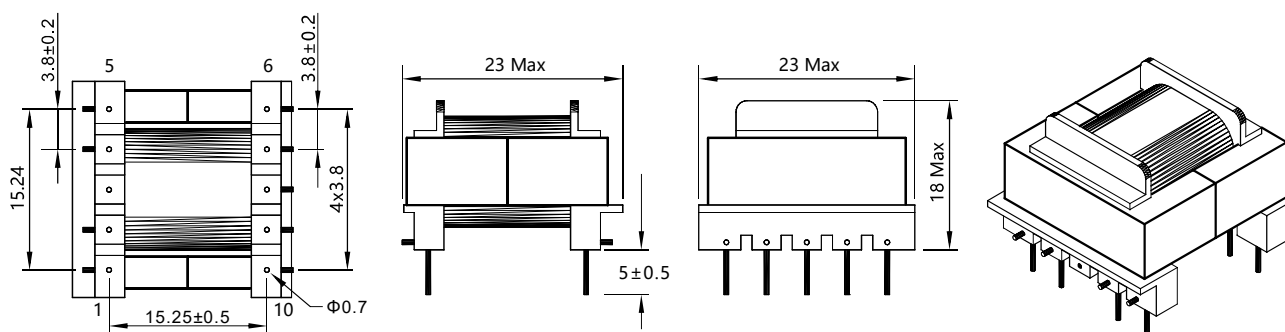

SCS 74030,74032 SERIES 15-30W E25 -3 or 10 UTPUT FLYBACK TRANSFORMERS

FEATURES

Primary / Secondary Insulation $\geq 4000V$
 Primary Auxiliary Insulation 1500V
 Creepage distances
 Primary/secondary $\geq 8mm$

Bulk packaging is standard
 Custom design available

AC-DC converters
 DC-DC converters
 Switch Power supplies
 FAPS: Flyback, Forward and Push-pull
 FAPS: Half Bridge and Full Bridge



Additional information:
 We reserve the right to make technical changes or modify the contents of this document without prior notice.
 SHARE Ltd. Does not accept any responsibility what so ever for potential errors or possible lack of information in this document.
 We can offer that even custom-made transformers will be covered by approvals from UL, CSA, KEMA, etc., but we will be happy to assist you in implementing them.
 New approvals may be required.



TECHNICAL INFORMATION

- Ambient temperature $< 50^{\circ}C$
- Construction confirms to CEI950, CEI335, CEI61558 for reinforced insulation
- Exclusively uses UL94-VO listed materials

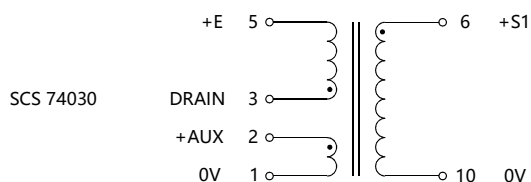
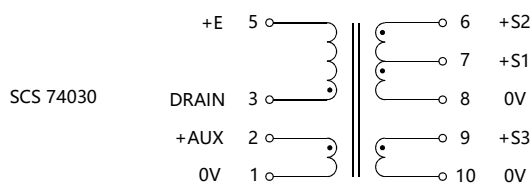

Note: PIN 3 Removed, PCB Drilling Diameter = 1.4mm

ELECTRICAL CHARACTERISTICS AT 25°C

P/N	Control IC Manufacturer	Control IC P/N	Input voltage	Power	Frequency
SCS 74030	Fairchild	KA1H0265R	85-265 Vrms	22 w	100 kHz
	Infineon	TDA16832	185-265 Vrms	30 w	100 kHz
	Motorola	MC33371	85-265 Vrms	22 w	100 kHz
	Motorola	MC33371	185-265 Vrms	30 w	100 kHz
	Power Integrations	TOP244P	185-265 Vrms	30 w	132 kHz
	Power Integrations	TOP244Y	85-265 Vrms	25 w	66/132kHz
	ST Microelectronics	VIPer50	85-265 Vrms	22 w	70 kHz
SCS74032	ST Microelectronics	VIPer50	185- 65 Vrms	30 w	70 kHz
	Power Integrations	TOP244P	185-265 Vrms	25 w	132 kHz

SIZE E25 - 3 or 1 OUTPUTS : 5 + 12/12v or 24v - FLYBACK TRANSFORMER

Part Number	Output Power max	Windings					
		Pins	Turns	Voltage	Current max	Inductance (+/-10%)	
SCS 74030	30W	Pri	3-5	70	65-130(VOR)	1.5Apeak	750μH
		Aux	2-1	8	7-14.5 Vdc	1 Adc	
		S1	7-8	4	3.3-7	3 Adc	
		S2	6-8	9	8-16 Vdc	1.5 Adc	
SCS 74032	35W	Pri	3-5	72	65-125 (VOR)	1.1 Apeak	1100μH
		Aux	2-1	10	8-16 Vdc	1 Adc	
		S1	6-10	18	15-30 Vdc	1.4 Adc	
		S2	9-10	9	8-16 Vdc	1.5 Adc	

Note to 74030 : S2 and S3 can be connected in series or in parallel

PHYSICAL CHARACTERISTICS(unit:mm)

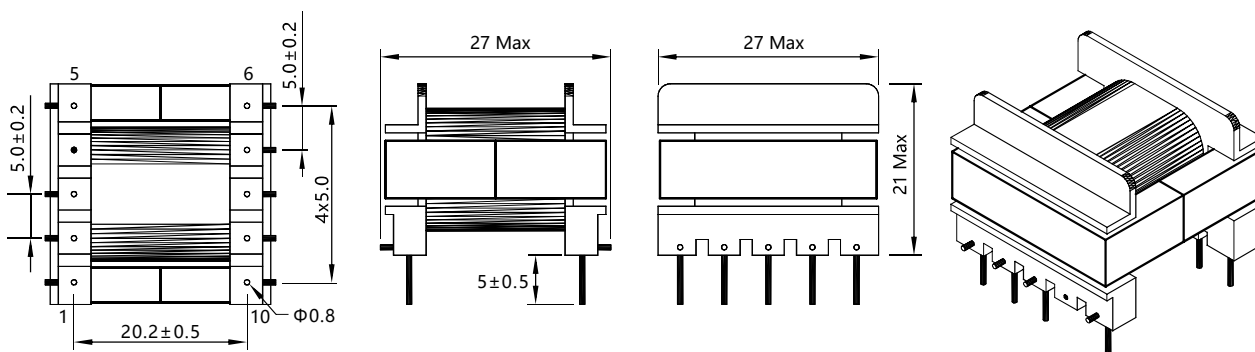

SCS 74043 SERIES 30-60W ERL28 -4 OUTPUT FLYBACK TRANSFORMERS

FEATURES

Primary / Secondary Insulation $\geq 4000V$
 Primary Auxiliary Insulation 1500V
 Creepage distances
 Primary/secondary $\geq 6mm$

Bulk packaging is standard
 Custom design available

AC-DC converters
 DC-DC converters
 Switch Power supplies
 FAPS: Flyback, Forward and Push-pull
 FAPS: Half Bridge and Full Bridge



Additional information:
 We reserve the right to make technical changes or modify the contents of this document without prior notice.
 SHARE Ltd. Does not accept any responsibility what so ever for potential errors or possible lack of information in this document.
 We can offer that even custom-made transformers will be covered by approvals from UL, CSA, KEMA, etc., but we will be happy to assist you in implementing them.
 New approvals may be required.



TECHNICAL INFORMATION

- Ambient temperature $< 50^{\circ}C$
- Construction confirms to CEI950, CEI335, CEI61558 for reinforced insulation
- Exclusively uses UL94-VO listed materials

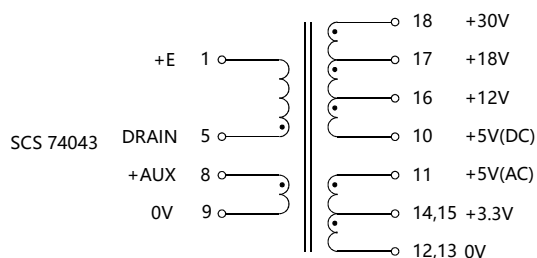

Note: PIN 3 Removed, PCB Drilling Diameter = 1.4mm

ELECTRICAL CHARACTERISTICS AT 25°C

Control IC Manufacturer	Control IC P/N	Input voltage	Power	Frequency
Power Integrations	TOP246Y	185-265Vrms	60 w	66/132 kHz
Power Integrations	TOP246Y	85-265Vrms	45 w	66/132 kHz

SIZE ETD29 - 4 OUTPUTS : 5 + 12/5 + 12v - FLYBACK TRANSFORMER

Part Number	Output Power max	Windings					
		Pins	Turns	Voltage	Current max	Inductance (+/-10%)	
SCS 74043	60W	Pri	5-1	45	90 (VOR)	3Apeak	500μH
		Aux	8-9	7	15 Vdc	0.5 Adc	
		S1	14+15/12+13	2	3.3 Vdc	7 Adc	
		S2	11/12+13	3	5 Vdc	sum S1+S2	
		S3	16-10	4	12 Vdc	2 Adc	
S4	17-10	7	18 Vdc	2 Adc			
S5	18-10	13	30 Vdc	0.5 Adc			

Note: Regulation with auxiliary winding

PHYSICAL CHARACTERISTICS(unit:mm)

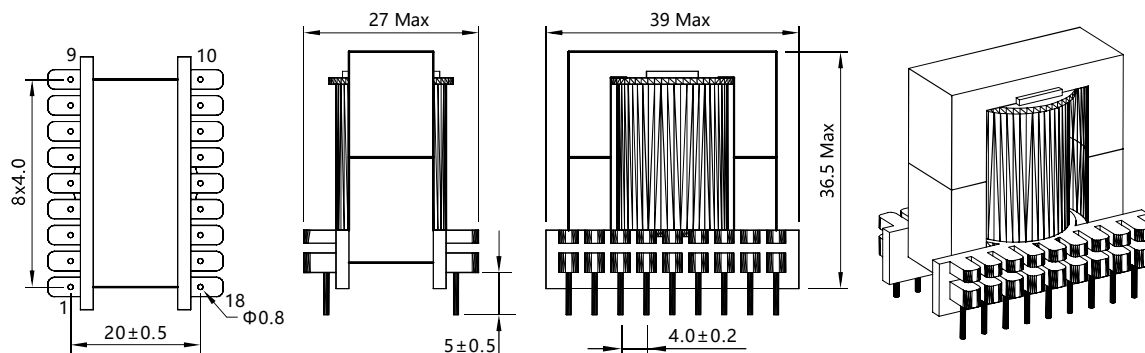

SCS 74050 SERIES 60-90W ETD34 -4 OUTPUT FLYBACK TRANSFORMERS



FEATURES

Primary / Secondary Insulation $\geq 4000V$
 Primary Auxiliary Insulation 1500V
 Creepage distances
 Primary/secondary $\geq 8mm$

Bulk packaging is standard
 Custom design available

AC-DC converters
 DC-DC converters
 Switch Power supplies
 FAPS: Flyback, Forward and Push-pull
 FAPS: Half Bridge and Full Bridge



Additional information:
 We reserve the right to make technical changes or modify the contents of this document without prior notice.
 SHARE Ltd. Does not accept any responsibility what so ever for potential errors or possible lack of information in this document.
 We can offer that even custom-made transformers will be covered by approvals from UL, CSA, KEMA, etc., but we will be happy to assist you in implementing them.
 New approvals may be required.

TECHNICAL INFORMATION

- Ambient temperature $< 50^{\circ}C$
- Construction confirms to CEI950, CEI335, CEI61558 for reinforced insulation
- Exclusively uses UL94-VO listed materials

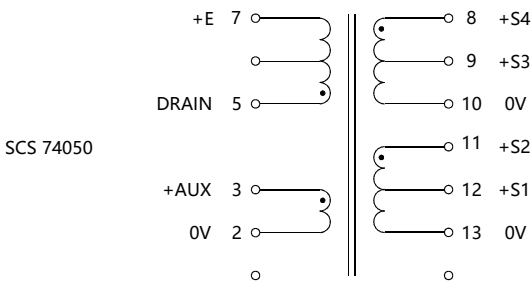

Note: PIN 4 Removed, PCB Drilling Diameter = 1.5mm

ELECTRICAL CHARACTERISTICS AT 25°C

Control IC Manufacturer	Control IC P/N	Input voltage	Power	Frequency
Infineon	TDA16834	185-265 Vrms	80 w	100 kHz
Infineon	TDA16836	85-265 Vrms	60 w	100 kHz
Motorola	MC33373	185-265 Vrms	80 w	100 kHz
Motorola	MC33373	85-265 Vrms	60 w	100 kHz
Power Integrations	TOP246Y	185-265 Vrms	90 w	132 kHz
Power Integrations	TOP246Y	85-265 Vrms	60 w	66/132kHz
ST Microelectronics	VIPer100A	185-265 Vrms	80 w	70 kHz
ST Microelectronics	VIPer100A	85-265 Vrms	60 w	70 kHz

SIZE ETD29 - 4 OUTPUTS : 5 + 12/5 + 12v - FLYBACK TRANSFORMER

Part Number	Output Power max	Pins	Turns	Windings			
				Voltage	Current max	Inductance (+/-10%)	
SCS 74050	90W	Pri	5-7	36	65-125(VOR)	2.8Apeak	500μH
		Aux	3-2	4	7-14 Vdc	0.5 Adc	
		S1	12-13	2	3.3-6.5	5 Adc	
		S2	11-13	5	8.5-17 Vdc	3 Adc	
		S3	9-10	2	3.3-6.5	5 Adc	
		S4	8-10	5	8.5-17 Vdc	3 Adc	

Note : S1/S3 or S2/S4 can be connected in series or in parallel

PHYSICAL CHARACTERISTICS(unit:mm)

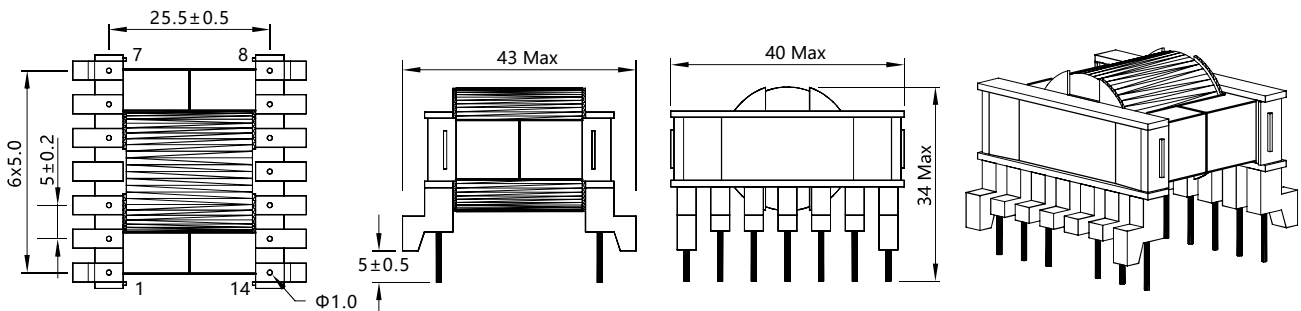

SCS 74060 SERIES 70-140W ETD39 - 4 OUTPUT FLYBACK TRANSFORMERS

FEATURES

Primary / Secondary Insulation $\geq 4000V$
 Primary Auxiliary Insulation 1500V
 Creepage distances
 Primary/secondary $\geq 8mm$

Bulk packaging is standard
 Custom design available

AC-DC converters
 DC-DC converters
 Switch Power supplies
 FAPS: Flyback, Forward and Push-pull
 FAPS: Half Bridge and Full Bridge



Additional information:
 We reserve the right to make technical changes or modify the contents of this document without prior notice.
 SHARE Ltd. Does not accept any responsibility what so ever for potential errors or possible lack of information in this document.
 We can offer that even custom-made transformers will be covered by approvals from UL, CSA, KEMA, etc., but we will be happy to assist you in implementing them.
 New approvals may be required.



TECHNICAL INFORMATION

- Ambient temperature $< 50^{\circ}C$
- Construction confirms to CEI950, CEI335, CEI61558 for reinforced insulation
- Exclusively uses UL94-VO listed materials

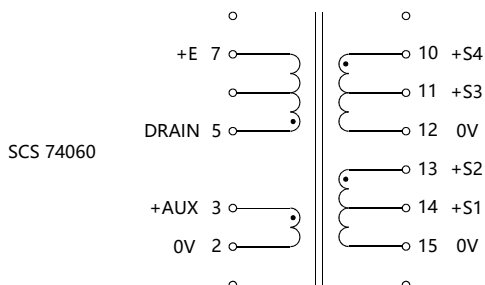

Note: PIN 4 Removed, PCB Drilling Diameter = 1.5mm

ELECTRICAL CHARACTERISTICS AT 25°C

Control IC Manufacturer	Control IC P/N	Input voltage	Power	Frequency
Fairchild	KA1H0565R	85-265Vrms	70 w	100 kHz
Fairchild	KA1H0565R	185-265Vrms	120 w	100 kHz
Infineon	TDA16836	85-265Vrms	70 w	100 kHz
Infineon	TDA16836	185-265Vrms	120 w	100 kHz
Motorola	MC33374	85-265Vrms	70 w	100 kHz
Motorola	MC33374	185-265Vrms	120 w	100 kHz
Power Integrations	TOP247Y	185-265Vrms	140 w	132 kHz
Power Integrations	TOP247Y	85-265Vrms	90 w	66/132 kHz
ST Microelectronics	VIPer100A	85-265Vrms	70 w	70 kHz
ST Microelectronics	VIPer100A	185-265Vrms	120 w	100 kHz

SIZE ETD39 - 4 OUTPUTS : 5 + 12/5 + 12v - FLYBACK TRANSFORMER

Part Number	Output Power max	Pins	Turns	Windings			
				Voltage	Current max	Inductance (+/-10%)	
SCS 74060	90W	Pri	5-1	36	65-125(VOR)	4 Apeak	
		Aux	3-2	4	7-14Vdc	0.5 Adc	
		S1	12-13	2	3.3-6.5Vdc	5 Adc	440μH
		S2	11-13	5	8.5-17Vdc	5 Adc	
		S3	9-10	2	12 Vdc	5 Adc	
		S4	5-10	5	18 Vdc	5 Adc	

Note: S1/S3 or S2/S4 can be connected in series or in parallel

PHYSICAL CHARACTERISTICS(unit:mm)

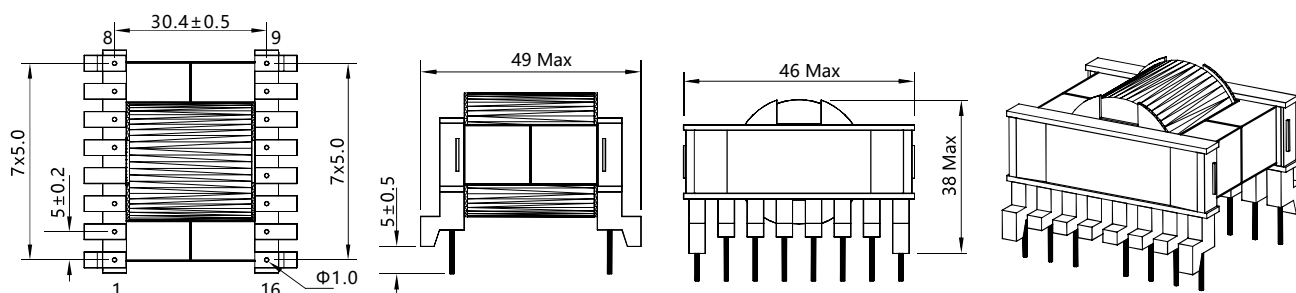

SCS 74070 SERIES 120-180W ETD44 - 4 OUTPUT FLYBACK TRANSFORMERS



FEATURES

Primary / Secondary Insulation $\geq 4000V$
 Primary Auxiliary Insulation 1500V
 Creepage distances
 Primary/secondary $\geq 8mm$

Bulk packaging is standard
 Custom design available

AC-DC converters
 DC-DC converters
 Switch Power supplies
 FAPS: Flyback, Forward and Push-pull
 FAPS: Half Bridge and Full Bridge



Additional information:
 We reserve the right to make technical changes or modify the contents of this document without prior notice.
 SHARE Ltd. Does not accept any responsibility what so ever for potential errors or possible lack of information in this document.
 We can offer that even custom-made transformers will be covered by approvals from UL, CSA, KEMA, etc., but we will be happy to assist you in implementing them.
 New approvals may be required.

TECHNICAL INFORMATION

- Ambient temperature $< 50^{\circ}C$
- Construction confirms to CEI950, CEI335, CEI61558 for reinforced insulation
- Exclusively uses UL94-VO listed materials

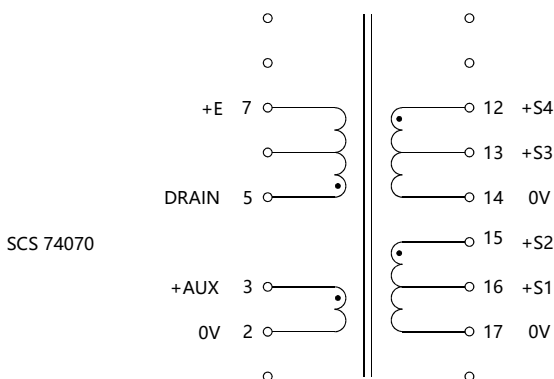

Note: PIN 4 Removed, PCB Drilling Diameter = 1.5mm

ELECTRICAL CHARACTERISTICS AT 25°C

Control IC Manufacturer	Control IC P/N	Input voltage	Power	Frequency
Fairchild	KA2S0965	185-265Vrms	160w	100 kHz
Infineon	TDA16837	185-265Vrms	160w	100 kHz
Philips	TEA1566	185-265Vrms	120w	50 kHz
Power Integrations	TOP248Y	185-265Vrms	180w	66/132kHz
Power Integrations	TOP249Y	85-265Vrms	120w	66 kHz

SIZE ETD44 - 4 OUTPUTS : 5 + 12 / 5 + 12v - FLYBACK TRANSFORMER

Part Number	Output Power max	Windings					
		Pins	Turns	Voltage	Current max	Inductance (+/-10%)	
SCS 74070	180W	Pri	5-7	38	65-125(VOR)	8 Apeak	300μH
		Aux	3-2	4	7-14 Vdc	0.5 Adc	
		S1	16-17	2	3.3-6.5	6 Adc	
		S2	15-17	5	8.5-17 Vdc	5 Adc	
		S3	13-14	2	3.3-6.5	6 Adc	
		S4	12-14	5	8.5-17 Vdc	5 Adc	

Note: S1/S3 or S2/S4 can be connected in series or in parallel

PHYSICAL CHARACTERISTICS(unit:mm)

